

# 5TE

*Water Content, EC  
and Temperature Sensors*

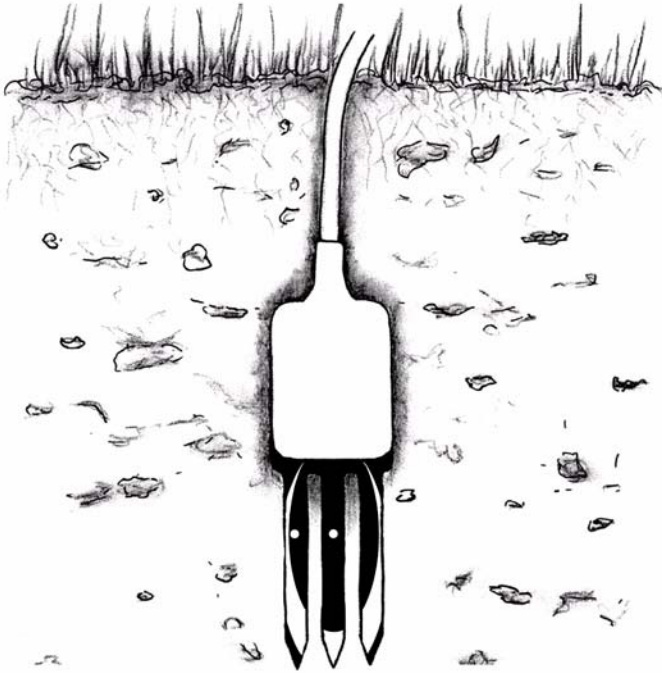

*Operator's Manual*  
Version 4



**Decagon Devices, Inc.**

2365 NE Hopkins Court

Pullman WA 99163

[www.decagon.com](http://www.decagon.com)

[soils@decagon.com](mailto:soils@decagon.com)

©2007-2010 Decagon Devices, Inc.

All rights reserved

# Contents

<b>1. Introduction</b>	<b>1</b>
Specifications	1
Contact Information	2
Warranty Information	3
Seller's Liability	3
<b>2. About the 5TE</b>	<b>4</b>
Background Info	4
<b>3. Theory</b>	<b>6</b>
Volumetric Water Content	6
Temperature	6
Electrical Conductivity	6
Converting Bulk EC to Pore EC	7
Pore Water vs. Solution EC	9
<b>4. Calibration</b>	<b>11</b>
Dielectric Permittivity	11
Mineral Soil Calibration	11
Calibration in Non-Soil Media	12
<b>5. Connecting to Logger</b>	<b>14</b>
Connecting to an Em50/Em50R logger	14
3.5mm Stereo Plug Wiring	15

---

---

Connecting to a Non-Decagon Logger . . . . .	15
Pigtail End Wiring . . . . .	16
<b>6. Communication . . . . .</b>	<b>18</b>
Serial Communication . . . . .	18
Dielectric Permittivity . . . . .	19
Electrical Conductivity . . . . .	19
Temperature . . . . .	20
SDI-12 Communication . . . . .	20
Sensor Bus . . . . .	20
Address . . . . .	21
Power . . . . .	21
Reading . . . . .	21
<b>7. Installing the Sensors . . . . .</b>	<b>23</b>
Procedure . . . . .	24
Orientation . . . . .	25
Removing the sensors . . . . .	26
Multiple sensor Installation . . . . .	26
<b>8. Campbell Scientific Programs . .</b>	<b>27</b>
<b>9. Troubleshooting&amp;Sensor Care .</b>	<b>28</b>
Datalogger . . . . .	28
Sensors . . . . .	28
Sensor Cleaning . . . . .	28
Cleaning Method . . . . .	30
<b>Declaration of Conformity . . . . .</b>	<b>31</b>

---

# 1. Introduction

---

Thank you for choosing Decagon's 5TE for measuring water content, temperature, and EC. This manual is designed to help you understand the sensor's features and how to use this device successfully.

## Specifications

### *Volumetric water content*

**Range:**

Apparent dielectric permittivity ( $\epsilon_a$ ): 1 (air) to 80 (water)

**Resolution:**

$\epsilon_a$ : 0.1  $\epsilon_a$  (unitless) from 1-20, <0.75  $\epsilon_a$  (unitless) from 20-80

VWC: 0.0008 m<sup>3</sup>/m<sup>3</sup> (0.08% VWC) from 0 to 50% VWC

**Accuracy:**

( $\epsilon_a$ ):  $\pm 1 \epsilon_a$  (unitless) from 1-40 (soil range),  $\pm 15\%$  from 40-80 (VWC):

- Using Topp equation:  $\pm 0.03 \text{ m}^3/\text{m}^3$  ( $\pm 3\%$  VWC) typical in mineral soils that have solution electrical conductivity < 10 dS/m
- Using medium specific calibration,  $\pm 0.01 - 0.02 \text{ m}^3/\text{m}^3$  ( $\pm 1-2\%$  VWC) in any porous medium

### *Electrical Conductivity (bulk)*

**Range:** 0-23 dS/m (bulk)

**Resolution:** 0.01 dS/m from 0 to 7 dS/m, 0.05 dS/m from 7 to 23 dS/m

**Accuracy:**  $\pm 10\%$  from 0 to 7 dS/m, user calibration required above 7 dS/m

---

## **5TE Operator's Manual**

### **1. Introduction**

---

#### *Temperature*

**Range:** -40-50 °C

**Resolution:** 0.1 °C

**Accuracy:** ±1 °C

#### *General*

**Dimensions:** 10 cm (l) x 3.2 cm (w) x 0.7 cm (d)

**Prong Length:** 5.2 cm

**Dielectric Measurement Frequency:** 70 MHz

**Measurement Time:** 150 ms (milliseconds)

**Power requirements:** 3.6 - 15 VDC, 0.3 mA quiescent, 10 mA during 150 ms measurement

**Output:** RS232 (TTL) or SDI-12

**Operating Temperature:** -40-50 °C

**Connector types:** 3.5 mm (stereo) plug or stripped & tinned lead wires (Pigtail)

**Cable Length:** 5m standard; custom cable length available upon request

**Datalogger Compatibility (not exclusive):**

Decagon: Em50, Em50R

Campbell Scientific: Any logger with serial I/O (CR10X, CR850, 1000, 3000, etc.)

## **Contact Information**

If you need to contact Decagon:

- **Call us** at 800-755-2751 or (509) 332-2756
- **Fax us** at (509) 332-5158
- **E-mail us** at [support@decagon.com](mailto:support@decagon.com).

---

## **Warranty Information**

All Decagon products have a 30-day satisfaction guarantee and a one-year warranty.

### **Seller's Liability**

Seller warrants new equipment of its own manufacture against defective workmanship and materials for a period of one year from date of receipt of equipment (the results of ordinary wear and tear, neglect, misuse, accident and excessive deterioration due to corrosion from any cause are not to be considered a defect); but Seller's liability for defective parts shall in no event exceed the furnishing of replacement parts F.O.B. the factory where originally manufactured. Material and equipment covered hereby which is not manufactured by Seller shall be covered only by the warranty of its manufacturer. Seller shall not be liable to Buyer for loss, damage or injuries to persons (including death), or to property or things of whatsoever kind (including, but not without limitation, loss of anticipated profits), occasioned by or arising out of the installation, operation, use, misuse, nonuse, repair, or replacement of said material and equipment, or out of the use of any method or process for which the same may be employed. The use of this equipment constitutes Buyer's acceptance of the terms set forth in this warranty. There are no understandings, representations, or warranties of any kind, express, implied, statutory or otherwise (including, but without limitation, the implied warranties of merchantability and fitness for a particular purpose), not expressly set forth herein.

## **2. About the 5TE**

---

The 5TE is designed to measure the water content, electrical conductivity, and temperature of soil and growing media. Using an oscillator running at 70 MHz, it measures the dielectric permittivity of soil to determine the water content. A thermistor in thermal contact with the sensor prongs provides the soil temperature, while the screws on the surface of the sensor form a two-sensor electrical array to measure electrical conductivity.

### **Background Info**

In 2006, Decagon incorporated research from its EC-5 volumetric water content sensor into the ECH<sub>2</sub>O-TE, a sensor which measured volumetric water content, temperature, and electrical conductivity. The new 5TE uses the same theory as the ECH<sub>2</sub>O-TE, but the location of the EC measurement is in the stainless steel screws instead of gold traces. The use of stainless steel screws has made the 5TE a more robust sensor. Additionally, the 5TE utilizes a 5 point dielectric calibration to provide dielectric permittivity measurements more accurate than the previous ECH<sub>2</sub>O-TE.



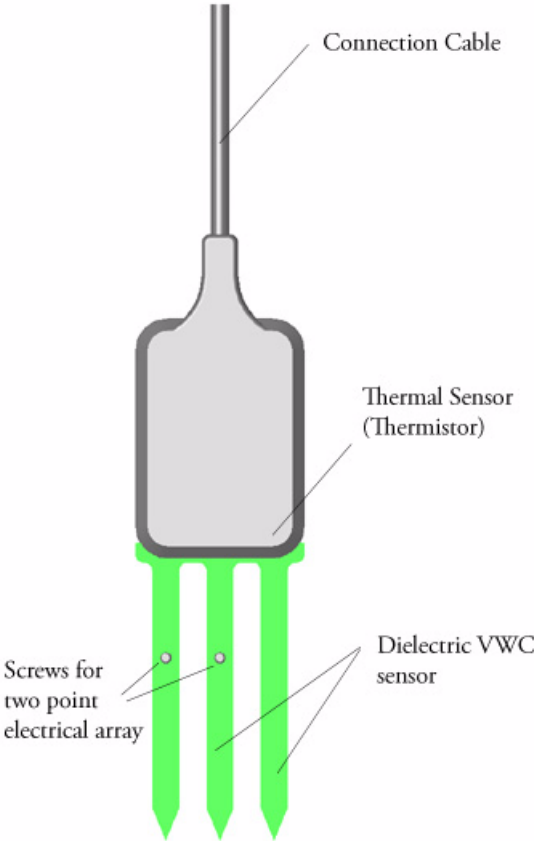

Figure 1: 5TE Components

## **3. Theory**

---

### **Volumetric Water Content**

The 5TE sensor uses an electromagnetic field to measure the dielectric permittivity of the surrounding medium. The sensor supplies a 70 MHz oscillating wave to the sensor prongs that charges according to the dielectric of the material. The stored charge is proportional to soil dielectric and soil volumetric water content. The 5TE microprocessor measures the charge and outputs a value of dielectric permittivity from the sensor.

### **Temperature**

The 5TE uses a surface-mounted thermistor to take temperature readings. It is located underneath the sensor overmold, next to one of the prongs, and will read the temperature of the prong surface. The 5TE will output temperature in °C unless otherwise stated in your preferences file in either the ECH<sub>2</sub>O DataTrac or ECH<sub>2</sub>O Utility programs.

It is important to note that if the black plastic overmold of the sensor is in direct sunshine, the temperature measurement may read high. Exposure of the overmold to solar radiation will also drastically decrease the life expectancy of the sensor. We do not recommend that the sensor be installed with the overmold in the sun.

### **Electrical Conductivity**

Electrical conductivity (EC) is the ability of a substance to conduct electricity and can be used to infer the amount of

---

polar molecules that are in solution. EC is measured by applying an alternating electrical current to two electrodes, and measuring the resistance between them. Conductivity is then derived by multiplying the inverse of the resistance (conductance) by the cell constant (the ratio of the distance between the electrodes to their area).

The 5TE uses a 2-sensor array to measure the EC. The array is located on the screws of two of the 5TE prongs. **Small amounts of oil from skin contact with the screws will cause significant inaccuracy in the EC measurement.** See the sensor cleaning section at the end of this manual for instructions on cleaning the sensors if contamination occurs.

The 5TE uses a two electrode array to measure the bulk EC of the surrounding medium. The bulk EC measurement is calibrated at the factory to be accurate within  $\pm 10\%$  from 0 to 7 dS/m. This range is adequate for most field, greenhouse and nursery applications. However, some special applications in salt affected soils may require measurements with bulk EC greater than the specified range. The 5TE will measure up to 23.1 dS/m bulk EC, but user calibration is required above 7 dS/m. Additionally, EC measurements above 7 dS/m are very sensitive to contamination of the electrodes by skin oils, etc. Be sure to read sensor cleaning section at the end of the manual if you plan to measure the EC of salty soils.

## **Converting Bulk EC to Pore EC**

For many applications, it is advantageous to know the electrical conductivity of the solution contained in the soil pores ( $\sigma_p$ ), which is a good indicator of the solute concentration in

---

## 5TE Operator's Manual

### 3. Theory

---

the soil. Traditionally,  $\sigma_p$  has been obtained by extracting pore water from the soil and measuring  $\sigma_p$  directly. As one would expect, this is a time consuming and labor intensive process.

The 5TE measures the electrical conductivity of the bulk soil surrounding the sensors ( $\sigma_b$ ). A considerable amount of research has been conducted to determine the relationship between  $\sigma_b$  and  $\sigma_p$ . Recent work by Hilhorst (2000), has taken advantage of the linear relationship between the soil bulk dielectric permittivity ( $\epsilon_b$ ) and  $\sigma_p$  to allow accurate conversion from  $\sigma_b$  to  $\sigma_p$  if the  $\epsilon_b$  is known. The 5TE measures  $\epsilon_b$  and  $\sigma_b$  nearly simultaneously in the same soil volume. It is therefore well suited to this method.

The pore water conductivity can be determined from (see Hilhorst, 2000 for derivation):

$$\sigma_p = \frac{\epsilon_p \sigma_b}{\epsilon_b - \epsilon_{\sigma_b=0}} \quad (1)$$

where  $\sigma_p$  is the pore water electrical conductivity (dS/m);  $\epsilon_p$  is the real portion of the dielectric permittivity of the soil pore water (unitless);  $\sigma_b$  is the bulk electrical conductivity, (dS/m), which is measured directly by the 5TE;  $\epsilon_b$  is the real portion of the dielectric permittivity of the bulk soil (unitless);  $\epsilon_{\sigma_b=0}$  is the real portion of the dielectric permittivity of dry soil (unitless).

$\epsilon_p$  can be calculated from soil temperature using:

$$\epsilon_p = 80.3 - 0.37 * (T_{soil} - 20) \quad (2)$$

---

where  $T_{soil}$  is the soil temperature (C) measured by the 5TE.

$\epsilon_b$  is also measured by the 5TE. Raw VWC counts can be converted to bulk dielectric by the ECH<sub>2</sub>O-TE dielectric calibration:

$$\epsilon_b = \frac{\epsilon_{Raw}}{50} \quad (3)$$

Finally,  $\epsilon_{\sigma_b} = 0$  is an offset term loosely representing the dielectric permittivity of the dry soil. Hilhorst (2000) recommended that  $\epsilon_{\sigma_b} = 4.1$  be used as a generic offset. However, our research in several agricultural soils, organic, and inorganic growth media indicates that  $\epsilon_{\sigma_b} = 6$  results in more accurate determinations of  $\sigma_p$ . Hilhorst (2000) offers a simple and easy method for determining for individual soil types, which will improve the accuracy of the calculation of  $\sigma_p$  in most cases.

Our testing indicates that the above method for calculating  $\sigma_p$  results in good accuracy ( $\pm 20\%$ ) in moist soils and other growth media. In dry soils where VWC is less than about  $0.10 \text{ m}^3/\text{m}^3$ , the denominator of equation 1 becomes very small, leading to large potential errors. We recommend that  $\sigma_p$  not be calculated in soils with  $\text{VWC} < 0.10 \text{ m}^3/\text{m}^3$  using this method.

## Pore Water vs. Solution EC

As noted in the previous section, pore water electrical conductivity can be calculated from bulk EC using the sensor-measured dielectric permittivity of the medium. However, pore water EC is not the same as solution EC. Pore water EC is the electrical conductivity of the water in the pore space of the soil. One could measure this directly if the soil was squeezed

---

## 5TE Operator's Manual

### 3. Theory

---

under high pressure to force water out of the soil matrix and that water was collected and tested for EC. Solution EC is the electrical conductivity of pore water removed from a saturated paste. In this case, the soil is wetted with distilled water until the soil saturates, then the soil is placed on filter paper in a vacuum funnel and suction is applied. An electrical conductivity measurement on the water removed from the sample will give the solution electrical conductivity. Theoretically, the two are related by the bulk density. An example calculation will illustrate this relationship: A soil is at  $0.1 \text{ m}^3/\text{m}^3$  VWC, has a pore water EC of  $0.7 \text{ dS/m}$ , and a bulk density of  $1.5 \text{ Mg/m}^3$ . We can calculate the solution EC as follows.

$$\phi = 1 - \frac{\rho_b}{\rho_s} = 1 - \frac{1.5}{2.65} = 0.43$$

$$\text{Solution EC} = \frac{\sigma_p \theta + \sigma_d (\phi - \theta)}{\phi} = \frac{0.7(0.1) + 0}{0.43} = 0.162 \text{ dS/m}$$

In this example,  $\phi$  is the porosity,  $\rho_b$  is bulk density,  $\rho_s$  is density of the minerals (assumed to be  $2.65 \text{ Mg/m}^3$ ), subscript  $d$  is distilled water, and  $\theta$  is volumetric water content. We assume that the EC of the distilled water is  $0 \text{ dS/m}$ . In practice, solution EC calculated from this method and solution EC taken from a laboratory soil test may not agree well because wetting soil to a saturated paste is very imprecise.

### Reference

Hilhorst, M.A. 2000. A pore water conductivity sensor. Soil Science Society of America Journal 64:6 1922-1925

## 4. Calibration

---

### Dielectric Permittivity

Each 5TE sensor has been calibrated to measure dielectric permittivity ( $\epsilon_a$ ) accurately in the range of 1 (air) to 80 (water). The unprocessed raw values reported by the 5TE in standard serial communication have units of  $\epsilon_a * 50$ . When used in SDI-12 communication mode, the unprocessed values have units of  $\epsilon_a * 100$ .

### Mineral Soil Calibration

Numerous researchers have studied the relationship between dielectric permittivity and volumetric water content (VWC) in soil. As a result, the soil science literature is littered with various transfer equations used to predict VWC from measured dielectric permittivity. You are free to use any of these various transfer equations to convert raw dielectric permittivity data from the 5TE into VWC. In Decagon's ProCheck reader and DataTrac and ECH<sub>2</sub>O Utility software packages, if the mineral soil calibration option is chosen, raw dielectric permittivity values from are converted to VWC using the well known Topp equation (Topp et al. 1980):

$$\text{VWC} = 4.3 \times 10^{-6} \epsilon_a^3 - 5.5 \times 10^{-4} \epsilon_a^2 + 2.92 \times 10^{-2} \epsilon_a - 5.3 \times 10^{-2}$$

Our tests have shown that a properly installed 5TE sensor installed in a normal mineral soil with saturation extract electrical conductivity <10 dS/m, the Topp equation will result in

---

## 5TE Operator's Manual

### 4. Calibration

---

measurements within  $\pm 3\%$  VWC of the actual soil VWC. If you require more accurate VWC than  $\pm 3\%$  or are working in a soil with very high electrical conductivity, or non-normal mineralogy, then it may be necessary to conduct a soil specific calibration for your 5TE sensor which will improve the accuracy to 1-2% for any soil. For more information on how to perform your own soil-specific calibration, or to have Decagon's calibration service perform one for you, visit us online at <http://www.decagon.com>.

## Calibration in Non-Soil Media

Decagon has performed calibrations with the 5TE in several non-soil growth media. The following are suggested calibration equations for some common materials.

### Potting Soil

$$\text{VWC} = 2.25 \times 10^{-5} \epsilon_a^3 - 2.06 \times 10^{-3} \epsilon_a^2 + 7.24 \times 10^{-2} \epsilon_a - 0.247$$

### Rockwool

$$\text{VWC} = -1.68 \times 10^{-3} \epsilon_a^2 + 6.56 \times 10^{-2} \epsilon_a + 0.0266$$

### Perlite

$$\text{VWC} = -1.07 \times 10^{-3} \epsilon_a^2 + 5.25 \times 10^{-2} \epsilon_a - 0.0685$$

Decagon will develop additional calibration equations for various other growth media as opportunities arise. Please check the Decagon website (<http://www.decagon.com>) or contact Decagon for the status of this ongoing research.

The 5TE can accurately read VWC in virtually any porous medium if a custom calibration is performed. For information on how to perform your own medium-specific calibration, or

---



to have Decagon's calibration service perform one for you, visit <http://www.decagon.com>.

**Reference**

Topp, G.C., J.L. David, and A.P. Annan 1980. Electromagnetic, Determination of Soil Water Content: Measurement in Coaxial Transmission Lines. *Water Resources Research* 16:3. p. 574-582.

## 5. Connecting to Logger

---

The 5TE sensor was designed to be used with Decagon's Em50, Em50R or the ProCheck handheld reader. The standard sensor (with 3.5 mm stereo connector) quickly connects to and is easily configured within a Decagon logger or selected in ProCheck.

The 5TE sensor incorporates several features that also make it an excellent sensor for use with third party loggers. The sensor may be purchased with stripped and tinned wires (pigtail) for terminal connections. Visit [www.decagon.com/support/literature](http://www.decagon.com/support/literature) to get extensive directions on how to integrate the 5TE sensor into third party loggers.

5TE sensor comes standard with a 5 meter cable. Sensors may be purchased with custom cable lengths for an additional fee (on a per-foot fee basis). Decagon has tested its digital sensor successfully up to 1000 meters (3200 ft). This option eliminates the need for splicing the cable (a possible failure point).

### **Connecting to an Em50/Em50R logger**

The 5TE has been designed to work specifically with the Em50 datalogger. Simply plug the 3.5mm "stereo plug" connector directly into one of the five sensor ports.

The next step is to configure your logger port for the 5TE and set the measurement interval, this may be done using either ECH<sub>2</sub>O Utility or ECH<sub>2</sub>O Utility Mobile (see respective man-

---

---

uals). Please check your software version to ensure it will support the 5TE. To update your software to the latest version, please visit Decagon's software download site: [www.decagon.com/support/downloads](http://www.decagon.com/support/downloads).

The following software support the 5TE sensor:

ECH<sub>2</sub>O Utility 1.12 or greater

ECH<sub>2</sub>O Utility Mobile 1.18 or greater

ECH<sub>2</sub>O DataTrac 2.77 or greater

To download data from the logger to your computer, you will need to use the ECH<sub>2</sub>O Utility, ECH<sub>2</sub>O DataTrac or a terminal program on your computer.

### **3.5mm Stereo Plug Wiring**

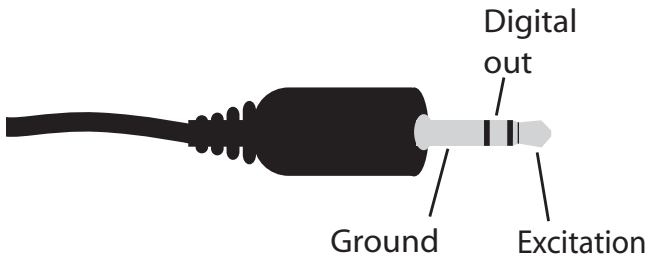

### **Connecting to a Non-Decagon Logger**

5TE sensor may be purchased for use with non-Decagon data loggers. These sensors typically come pre-configured with stripped and tinned (pigtail) lead wires for use with screw terminals. Refer to your distinct logger manual for details on wiring. Our integrator's guide gives detailed instructions on

## 5TE Operator's Manual

### 5. Connecting to Logger

---

connecting the 5TE sensor to non-Decagon loggers. Please visit [www.decagon.com/support/literature](http://www.decagon.com/support/literature) for the complete integrator's guide.

### **Pigtail End Wiring**

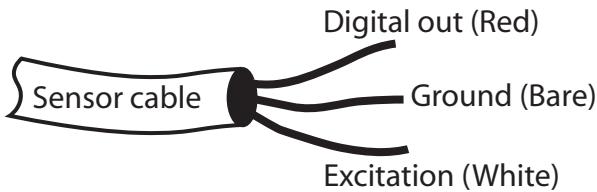

Connect the wires to the data logger as shown, with the supply wire (white) connected to the excitation, the digital out wire (red) to a digital input, the bare ground wire to ground as illustrated below.

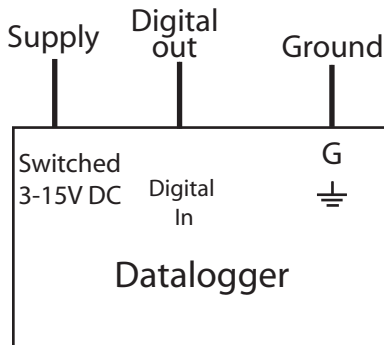

*NOTE: The acceptable range of excitation voltages is from 3-15 VDC. If you wish to read the 5TE with the Campbell Scientific Data Loggers, you will need to power the sensors off of the switched 12V port.*

If your 5TE is equipped with the standard 3.5mm plug, and you wish to connect it to a non-Decagon datalogger, you have two options. First, you can clip off the plug on the sensor cable, strip and tin the wires, and wire it directly into the datalogger. This has the advantage of creating a direct connection with no chance of the sensor becoming un-plugged; however, it then cannot be easily used in the future with a Decagon readout unit or datalogger.

The other option is to obtain an adapter cable from Decagon. The 3-wire sensor adapter cable has a connector for the sensor jack on one end, and three wires on the other end for connection to a datalogger (this type of wire is often referred to as a "pigtail adapter"). Both the stripped and tinned adapter cable wires have the same termination as seen above; the white wire is excitation, red is output, and the bare wire is ground.

## **6. Communication**

---

The 5TE sensor can communicate using two different methods, Serial (TTL) and SDI-12. In this chapter we will briefly discuss the specifics of each of these communication methods. Please visit [www.decagon.com/support/literature](http://www.decagon.com/support/literature) for the complete integrator's guide, which gives more detailed explanations and instructions.

### **Serial Communication**

When excitation voltage is applied, the 5TE makes a measurement. Within about 120 ms of excitation three measurement values are transmitted to the data logger as a serial stream of ASCII characters. The serial out is 1200 baud asynchronous with 8 data bits, no parity, and one stop bit. The voltage levels are 0-3.6V and the logic levels are TTL (active low). The power must be removed and reapplied for a new set of values to be transmitted.

The ASCII stream contains 3 numbers separated by spaces. The stream is terminated with the carriage return character. The first number is raw dielectric output. The second number is 0 (ignore this value) and the third number is raw temperature. The following explains how to convert the raw values into their standard units.

---

## **Dielectric Permittivity**

The raw dielectric value ( $\epsilon_{Raw}$ ), is valid in the range 0 to 4094. This corresponds to dielectric permittivity values 0.00 to 81.88. The 5TE uses the  $\epsilon_{Raw}$  value of 4095 to indicate the dielectric permittivity portion of the sensor is not working as expected.

The  $\epsilon_{Raw}$  value is converted to dielectric permittivity with the following equation:

$$\text{Dielectric Permittivity} = \epsilon_a = \frac{\epsilon_{Raw}}{50}$$

## **Electrical Conductivity**

The raw electrical conductivity value ( $\sigma_{Raw}$ ), is valid in the range 0 to 1022. The 5TE uses a compression algorithm to extend the range of electrical conductivity that can be represented by a 10-bit value.  $\sigma_{Raw}$  can be converted to bulk electrical conductivities using the following algorithms.

$$\text{If } \sigma_{Raw} \leq 700 \text{ then EC (dS/m)} = \frac{\sigma_{Raw}}{100}$$

$$\text{If } \sigma_{Raw} > 700 \text{ then EC (dS/m)} = \frac{700 + 5(\sigma_{Raw} - 700)}{100}$$

Electrical conductivities above 23.1 are truncated to this maximum value. The 5TE uses the  $\sigma_{Raw}$  value of 1023 to indicate the electrical conductivity portion of the sensor is not working as expected.

---

**Temperature**

The raw temperature value, ( $T_{Raw}$ ), is valid in the range 0 to 1022. The 5TE uses a compression algorithm to extend the range of temperatures that can be represented by a 10-bit value. The sensor sends temperature with 1/10 of a degree Celsius resolution for the range -40 to 50.0°C. For the range 50.5 to 111.0 the sensor sends temperature with a .5 of a degree resolution. Temperatures outside this range are truncated to the maximum or minimum values as appropriate. The 5TE uses the  $T_{Raw}$  value of 1023 to indicate the temperature portion of the sensor is not working as expected.

$$\text{If } T_{Raw} \leq 900 \quad \text{then } T_{Raw2} = T_{Raw}$$

$$\text{If } T_{Raw} > 900 \quad \text{then } T_{Raw2} = 900 + 5 (T_{Raw} - 900)$$

$$\text{Temperature}(\text{°C}) = (T_{Raw2} - 400) / 10$$

**SDI-12 Communication**

The 5TE sensor can also communicate using the SDI-12 protocol, a three-wire interface where all sensors are powered (white wire), grounded (bare wire), and communicate (red wire) on shared wires (for more info, go to [www.sdi-12.org](http://www.sdi-12.org)). Below is a brief description of SDI-12 for communication. If you plan on using SDI-12 for communication with the 5TE, please see our integrator's guide at [www.decagon.com/support/literature](http://www.decagon.com/support/literature) for detailed instructions.

**Sensor Bus**

There are both positive and negative elements of the SDI-12 protocol. On the positive side, up to 62 sensors can be connected to the same 12 V supply and communication port on

---



the datalogger. This simplifies wiring because no multiplexer is necessary. On the negative side, one sensor problem can bring down the entire array (through a short circuit, etc.). To avoid this problem, we recommend the user make an independent junction box with wire harnesses where all sensor wires are wired to wire lugs so sensors can be disconnected if a problem arises. A single three-wire bundle can be run from the junction box to the datalogger.

## **Address**

The SDI-12 protocol requires that all sensors have a unique address. 5TE sensors come from the factory with an SDI-12 address of 0. To add more than one SDI-12 sensor to a system, the sensor address must be changed. Address options include {0...9, A...Z, a...z}. The best and easiest way to change an address is to use Decagon's ProCheck (if the option is not available on your ProCheck, please upgrade to the latest version of firmware). SDI-12 addressing can be accessed in the "CONFIG" menu by selecting "SDI-12 Address". Addresses may then be changed by simply pressing the up or down arrows until you see the desired address and pushing "Enter".

## **Power**

The sensor can be powered using any voltage from 3.6 to 15 VDC, but 12 V is optimal. Although SDI-12 protocol allows the sensors to be continuously powered, you may connect the power (white wire) to a switching source. This can help reduce power use (although the 5TE sensors use very little power).

## **Reading**

SDI-12 communication allows many parameters to be communicated at once. This allows you to see information such as the sensor model, SDI-12 version, temp, etc.

---

## 5TE Operator's Manual

### 6. Communication

---

Reading the 5TE sensor in SDI-12 mode requires function calls. An example program from Edlog and CRBasic can be found in our software section online at <http://www.decagon.com/support/downloads>.

The dielectric permittivity ( $\epsilon$ ) is the first number output by the sensor. It is converted to volumetric water content (VWC) using Topp et al. (1980):  $\theta \text{ (m}^3\text{/m}^3\text{)} = 4.3 \times 10^{-6} * \epsilon^3 - 5.5 \times 10^{-4} * \epsilon^2 + 2.92 \times 10^{-2} * \epsilon - 5.3 \times 10^{-2}$ . The second number is electrical conductivity, in dS/m. The third number is temperature in Celsius.

The SDI-12 communication protocol is supported in Campbell Scientific dataloggers like the CR10X, CR200, CR1000, CR3000, etc. Direct SDI-12 communication is supported in the “Terminal Emulator” mode under the “Tools” menu on the “Connect” screen. Detailed information on setting the address using CSI dataloggers can be found on our website at <http://www.decagon.com/support/downloads>.

## **7. Installing the Sensors**

---

*NOTE 1: Make sure the screw electrodes on the 5TE are clean before installing the sensors. See the sensor cleaning section at the end of the manual.*

*NOTE 2: If you are installing sensors in a lightning prone area with a grounded data logger, please see our application note at [www.deca-gon.com/sensorappnotes](http://www.deca-gon.com/sensorappnotes).*

*NOTE 3: Decagon advises that you test the sensors with your data logging device and software before going to the field.*

Before you select a site for installation, remember that the soil next to the sensor surface has the strongest influence on its readings. It is important to avoid air gaps or extremely compact soil around the sensor, which can skew readings. Do not install the 5TE next to large metal objects, which can attenuate the sensors' electromagnetic field and distort output readings. Because the sensors have gaps between their prongs, it is also important to consider the size of the media you are inserting the sensor into. It is possible to get sticks, bark, roots or other material stuck between the sensorsensor prongs, which will adversely affect readings. Finally, be careful when inserting the sensors into dense soil, as the prongs can break if excessive force is used when pushing them in.

---

## **Procedure**

The 5TE can be inserted directly into growing media or soil. The tip of each prong has been sharpened to make it easier to push the sensor in. *Be careful around the sharpened tips!* The sensor needs to be completely covered by soil, as shown in Figure 2.

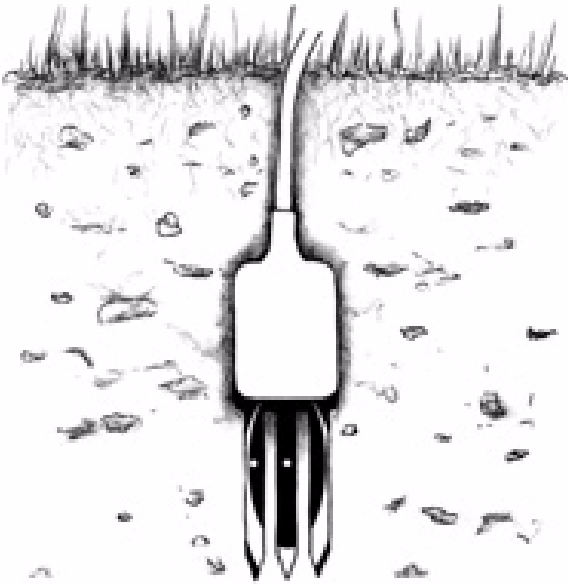

*Figure 2: 5TE installed correctly*

The sensors may be difficult to insert into extremely compact or dry soil. If you have difficulty inserting the sensor, try loosening the soil somewhat or wetting the soil. Never pound the sensor in.

**Method 1. : Horizontal Installation**

Excavate a hole or trench a few centimeters deeper than the depth at which the sensor is to be installed. At the installation depth, shave off some soil from the vertical soil face exposing undisturbed soil. Insert the sensor into the undisturbed soil face until the entire sensing portion of the 5TE is inserted. The tip of each prong has been sharpened to make it easier to push the sensor in. Be careful with the sharp tips! Backfill the trench taking care to pack the soil back to natural bulk density around the black plastic portion of the 5TE.

**Method 2.: Vertical Installation**

Auger a 4-inch hole to the depth at which the sensor is to be installed. Insert the sensor into the undisturbed soil at the bottom of the auger hole using your hand or any other implement that will guide the sensor into the soil at the bottom of the hole. Many people have used a simple piece of PVC pipe with a notch cut in the end for the sensor to sit in, with the sensor cable routed inside the pipe. After inserting the sensor, remove the installation device and backfill the hole taking care to pack the soil back to natural bulk density while not damaging the black plastic portion of the sensor or the sensor cable in the process.

**Orientation**

The 5TE can be oriented in any direction. Because the sensors have prongs instead of a blade (like the EC-10 and EC-20), the sensor can be placed in any orientation that meets your requirements.

---

## **Removing the sensors**

When removing the 5TE sensor, do not pull it by the cable! This could break the internal wires and cause the sensor to malfunction or not function at all.

## **Multiple sensor Installation**

The 5TE sensor makes electrical conductivity (EC) measurements by exciting one screw on the sensor and measuring the current that moves from that screw to the adjacent screw that is grounded. The distance between the screws is an important part of the EC calculation. If 5TE sensors are placed close together (within 20cm), it is possible for some of the current that leaves the excited screw to pass through the nearby sensor's ground screw, thus producing an erroneous sensor reading.

This problem occurs regardless of what logging system you are using if the ground wires are connected at all times. If you must have your sensors close together, (i.e. column experiments, etc) consider a multiplexing option that would isolate the ground wires.

If you are installing sensors vertically at short depth intervals, do not bury them directly over the top of each other. Although at times the vertical distance may be less than 20cm, the sensors can be staggered horizontally so they are not directly above each other, thus meeting the distance requirement.

## **8. Campbell Scientific Programs**

---

Because the sensors uses digital rather than analog communication, they require special considerations when connecting to a Campbell Scientific datalogger. Please visit our website at <http://www.decagon.com/support/downloads> to view sample Campbell Scientific programs.

## **9. Troubleshooting & Sensor Care**

---

If you encounter problems with the 5TE sensor, they most likely will manifest themselves in the form of incorrect or erroneous readings. Before contacting Decagon about the sensor, do the following:

### **Datalogger**

1. Check to make sure the connections to the data logger are both correct and secure.
2. Ensure that your data logger's batteries are not dead or weakened.
3. Check the configuration of your data logger in ECH<sub>2</sub>O Utility or ECH<sub>2</sub>O DataTrac to make sure you have selected 5TE.

### **Sensors**

1. Ensure that your sensors are installed according to the "Installation" section of this manual.
2. Check sensor cables for nicks or cuts that could cause a malfunction.
3. Check your electrical conductivity sensor screws to ensure that they are not damaged or contaminated.

### **Sensor Cleaning**

The EC measurement is very sensitive to the presence of non-conducting contamination on the screws, especially at high

---



EC. The most common source of contamination is skin oil from handling the screws traces with bare hands. Figure 3a and 3b show the simplified electrical circuit resulting from a finger print on the screw in a low EC soil and high EC soil, respectively. It is apparent that in a low EC soil, the effects of contamination are relatively small, because the resistance in the soil dominates the total resistance. However, in a high EC soil, the effects of contamination become very large. This demonstrates the need to keep the screws clean, especially when the sensor is to be used in high EC soil. Contamination of the screws during handling and shipping prevent the factory calibration from being valid past 8 dS/m, although the sensors will measure accurately at much higher EC with proper cleaning and calibration by the user.

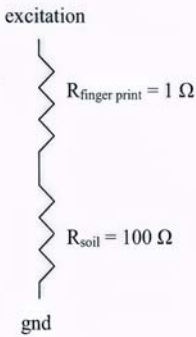

*Figure 3a: Simplified circuit of contaminated sensor in low EC (high resistance) soil.  $R_{total}=101\Omega$ , fingerprint causes 1% error.*

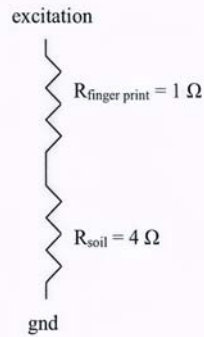

*Figure 3b: Simplified circuit of contaminated sensor in high EC (low resistance) soil.  $R_{total}=5\Omega$ , fingerprint causes 25% error*

## **Cleaning Method**

1. Wash the screws thoroughly with a drop of Dawn or other grease cutting dish soap and warm water. Be sure that the soap doesn't contain skin conditioners or moisturizers.
2. Rinse the sensor and screws thoroughly with tap water to remove all remnants of soap.
3. Dry the screws with a clean paper towel. Use a scrubbing motion to dry the screws to be sure any particles have been detached. Be sure that the paper towel does not have any skin conditioners or moisturizers in it, as this will undo all of the cleaning that you have just accomplished.

Be sure not to touch the screws with an un-gloved hand or to contact them with any source of oil or other non-conducting residue.

# Declaration of Conformity

Application of Council Directive:89/336/EE6

**Standards to Which Conformity  
is Declared:** EN61326 : 1998  
EN51022 : 1998

**Manufacturer's Name:** Decagon Devices, Inc.  
2365 NE Hopkins Court  
Pullman, WA 99163 USA

**Type of Equipment:** Dielectric soil  
moisture sensor

**Model Number:** ECH<sub>2</sub>O-TE/EC-TM/5TE/5TM

**Year of First Manufacture:** 2005

This is to certify that the ECH<sub>2</sub>O-TE, EC-TM, 5TE and 5TM dielectric soil moisture sensors, manufactured by Decagon Devices, Inc., a corporation based in Pullman, Washington, USA meet or exceed the standards for CE compliance as per the Council Directives noted above. All instruments are built at the factory at Decagon and pertinent testing documentation is freely available for verification.

# Index

## **B**

Bulk EC 7

## **C**

Campbell Scientific Programs 27

Cleaning

*probe* 30

*screws* 30

Communication 18

*SDI-12* 20

*Serial (RS232)* 18

Contact information 2

Converting bulk EC to pore EC 7

CSI loggers

*using 5TE probes with* 27

## **D**

Declaration of conformity 31

Dielectric permittivity 11, 19

## **E**

ECH2O Utility 1.10 14, 15

Electrical conductivity 6

## **H**

Horizontal installation 24

How the TE works

*electrical conductivity* 6

*temperature* 6

*volumetric water content* 6

**I**

Installation

*orientation* 25

*removing the probe* 26

**L**

Logger

*Non Decagon* 15

Logger communication 17

**M**

Mineral soil calibration 11

**P**

Perlite Calibration 12

Pore water EC 7

Potting Soil Calibration 12

Power requirements 2

**R**

Raw values 19

Rockwool Calibration 12

**S**

Screws 7

Seller's liability 3

Sensor accuracy 1

sensor cleaning 29

Sensor components 5

Sensor installation 23

Sensor range 1

Sensor resolution 1

Solution EC 9

Specifications 1

**T**

Temperature

*how 5TE measures* 6

Temperature 6, 20

Troubleshooting 28

**V**

Vertical installation 25

Volumetric water content 6

**W**

Warranty information 3

Wiring

*Pigtail* 16

*Stereo Plug* 15